

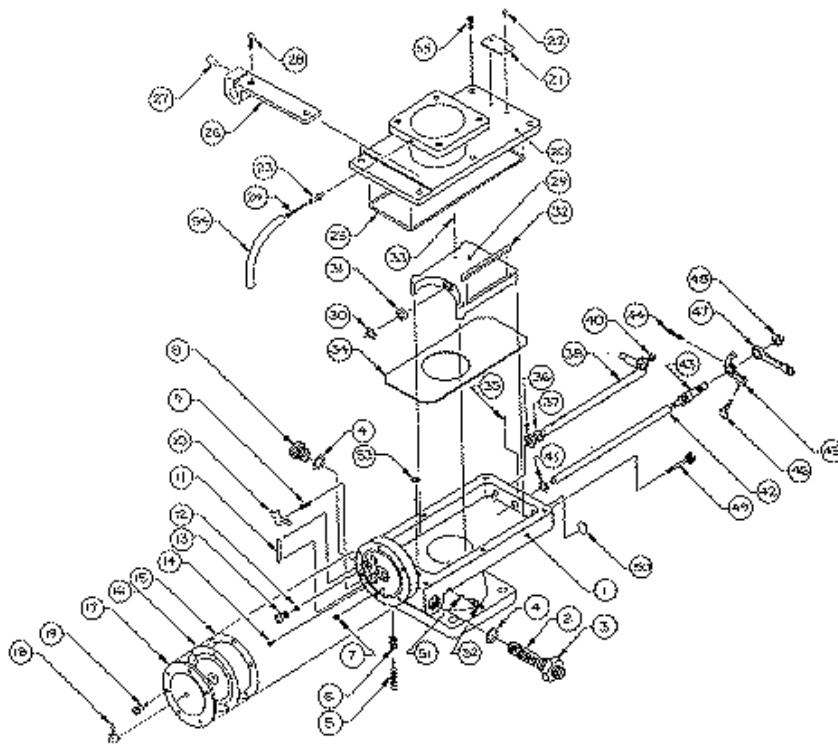

Your source for information and technical support for the
Ellison Throttle Body Injector

- Home
- Products
- Applications
- Articles
- Purchase
- Support
- FAQ's
- Contact Us

Appendix A - Exploded View



Click image for [full size diagram](#) (45K).

PARTS I.D. LIST

FIG. #	DESCRIPTION
1	MAIN BODY
2	SCREEN, FUEL STRAINER
3	FITTING, ADAPTER
4	SEAL, VITON
5	VALVE, MIXTURE NEEDLE
6	SPRING, MIXTURE NEEDLE
7	PLUG, UPSET

8	PLUG, BLEEDER
9	SPRING, CONTROL LEVER
10	ARM, CONTROL LEVER
11	AXLE, CONTROL LEVER
12	SEAL, VITON
13	VALVE, INLET CONTROL
14	SCREW, AXLE
15	GASKET, REGULATOR
16	ASSY., DIAPHRAGM
17	COVER, REGULATOR
18	FITTING, ELBOW
19	SCREW, REG. COVER
20	COVER, INLET FLANGE
21	PLATE, NAME
22	RIVET, DRIVE
23	FITTING, TOTAL REF.
24	TUBE, REG. TOTAL REF.
25	SEAL, BUNA CORD
26	CLAMP, CABLE
27	SCREW, CABLE CLAMP
28	SCEW, INLET COVER/CABLE CLAMP
29	SLIDE, THROTTLE
30	RETAINER, SLIDE SEAL
31	SEAL, BAL. SLIDE SEAL
32	BEARING, TEFLON
33	PIN, ROLL, RETAINING, THROTTLE ROD TO SLIDE
34	INSERT, TEFLON
35	PIN, ROLL, RETAINING, END SHAFT
36	SEAL, BAL. THROTTLE ROD
37	RETAINER, THROTTLE ROD SEAL
38	ROD, THROTTLE ACT.
39	NUT, THROTTLE ROD
40	SCREW, IDLE SPEED
41	SEAL, TEFLON
42	TUBE, FUEL METERING
43	SHAFT, END
44	PIN, ROLL, RETAINING, MIXTURE STOP TO END SHAFT
45	STOP, MIXTURE
46	SCREW, MIXTURE STOP
47	ARM, MIXTURE
48	NUT, END SHAFT
49	SCREW, THROTTLE STOP
50	PLUG, ALT. THROTTLE HOLE
51	BALL CHECK
52	FITTING, DRAIN OPT.
53	SEAL, DRILLED PASS.

54	TUBING, PRESS. REF.
55	SCREW, INLET COVER

909-906-1472

909-906-1473 Fax

Site Map - ellison

Ellison-Fluid-Systems, Inc.

23052H Alicia Pkwy #395

Mission Viejo, Ca. 92692

info@ellison-fluid-systems.com

[Webmaster](#)